

TIPO P

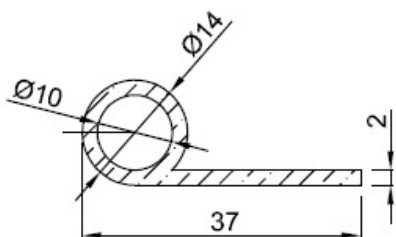

2770

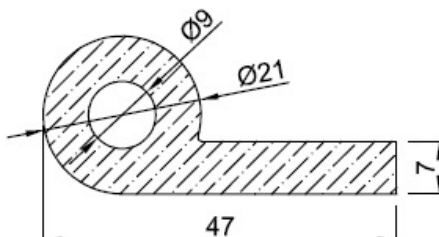

162

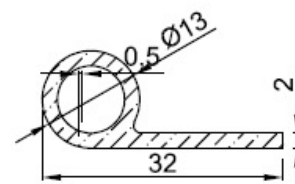

2008

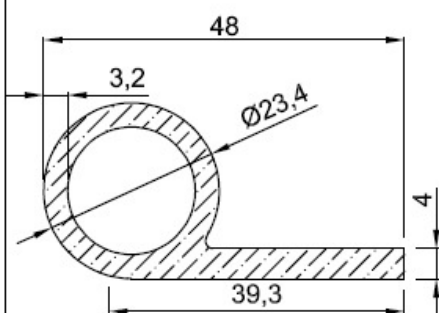

2621

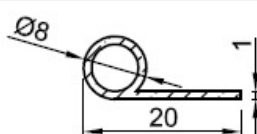

2052

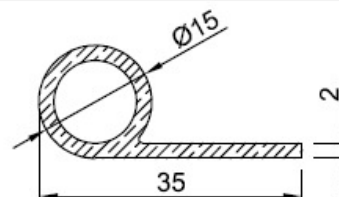

2382

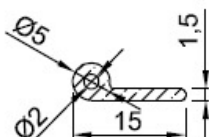

2738

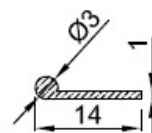

1267

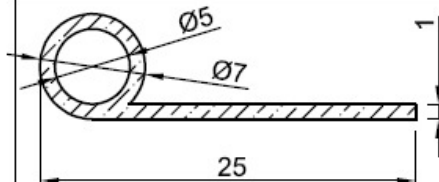

2043

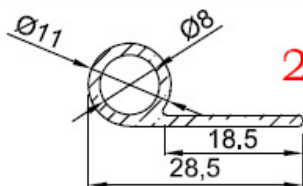

2216

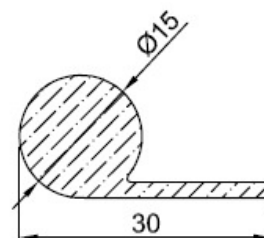

1909

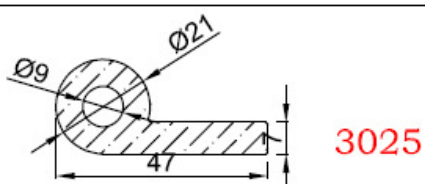

3025

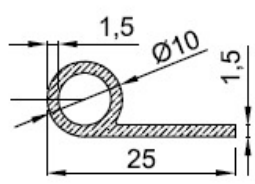

1525

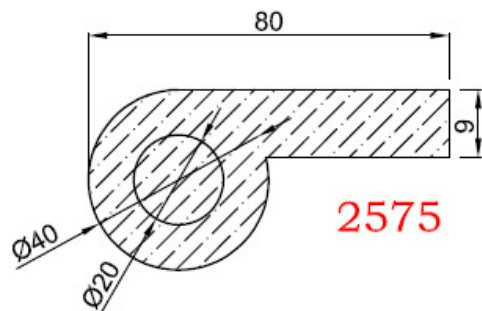

2575

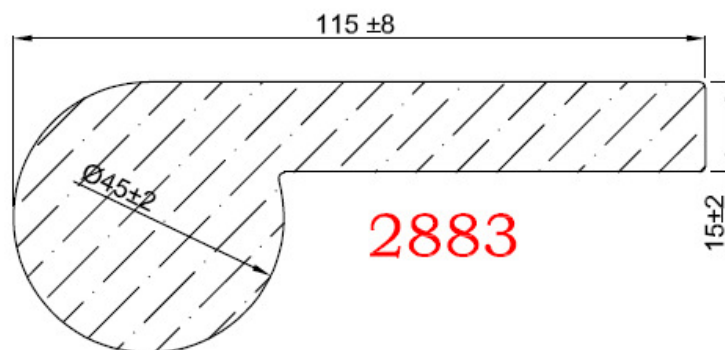

2883

TOLLERANZE DIMENSIONALI DEI TRAFILATI IN GOMMA SECONDO UNI ISO 3302

| da mm | 0,0 | 1,6 | 2,6 | 4,1 | 6,4 | 10,1 | 16,1 | 25,1 | 40,1 | 63,1 |
|--------|-------|-------|-------|-------|-------|-------|-------|-------|-------|-------|
| a | 1,5 | 2,5 | 4,0 | 6,3 | 10,0 | 16,0 | 25,0 | 40,0 | 63,0 | 100,0 |
| Classe | | | | | | | | | | |
| E2 | ±0,25 | ±0,35 | ±0,40 | ±0,50 | ±0,70 | ±0,80 | ±1,00 | ±1,30 | ±1,60 | ±2,00 |

TIPO P

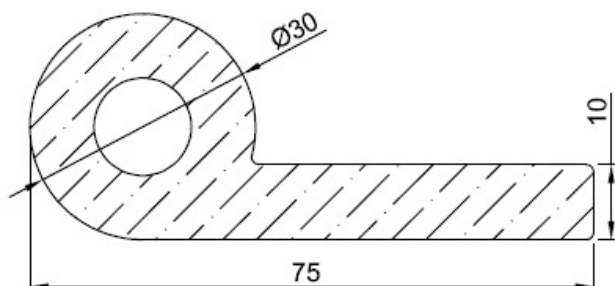

2644

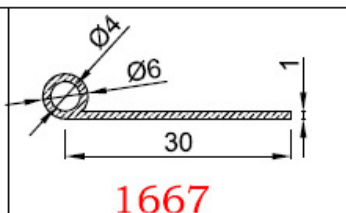

1667

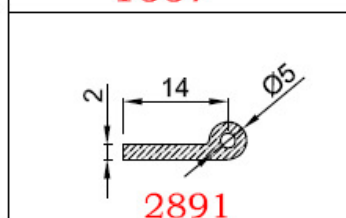

2891

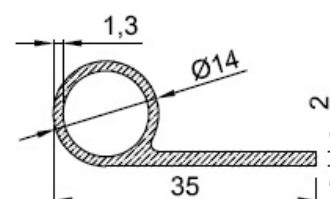

2001

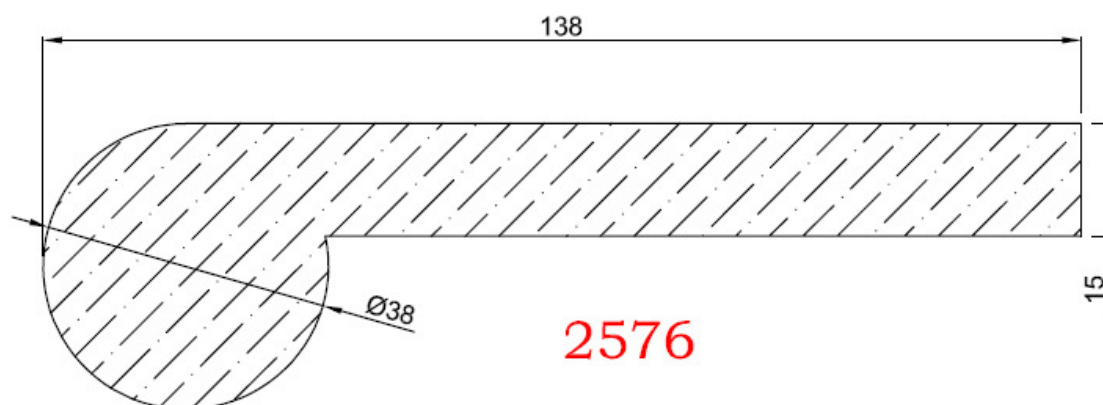

2576

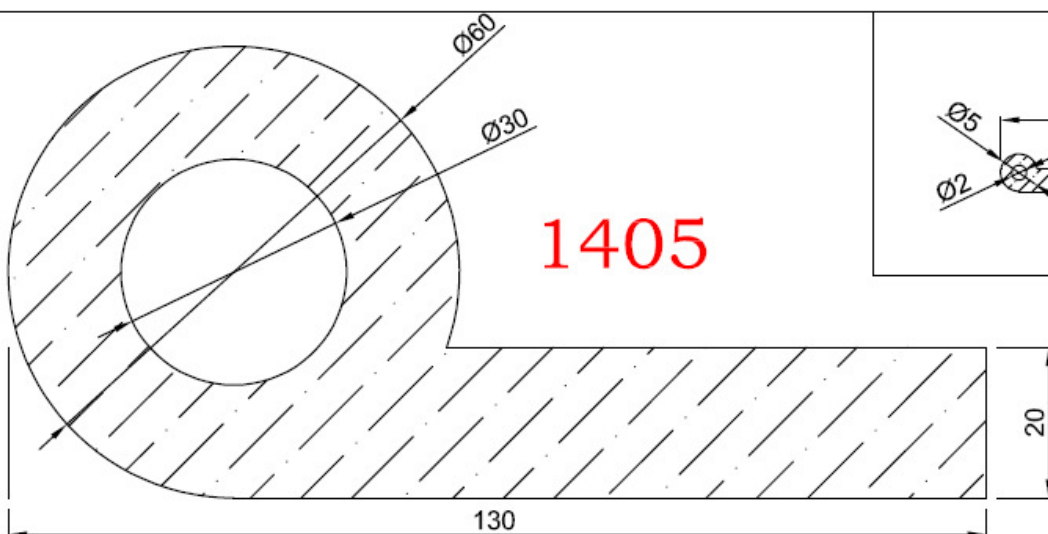

1405

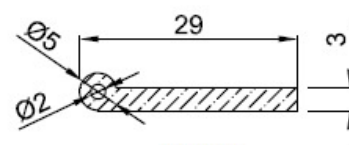

3009

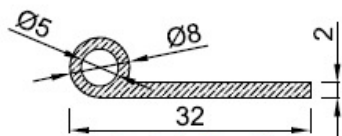

1526

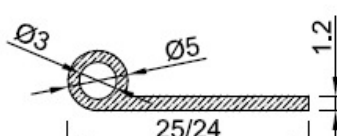

1527

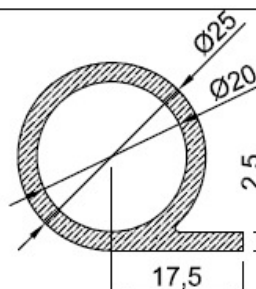

1901

TOLLERANZE DIMENSIONALI DEI TRAFILATI IN GOMMA SECONDO UNI ISO 3302

| da mm | 0,0 | 1,6 | 2,6 | 4,1 | 6,4 | 10,1 | 16,1 | 25,1 | 40,1 | 63,1 |
|--------|-------|-------|-------|-------|-------|-------|-------|-------|-------|-------|
| a | 1,5 | 2,5 | 4,0 | 6,3 | 10,0 | 16,0 | 25,0 | 40,0 | 63,0 | 100,0 |
| Classe | | | | | | | | | | |
| E2 | ±0,25 | ±0,35 | ±0,40 | ±0,50 | ±0,70 | ±0,80 | ±1,00 | ±1,30 | ±1,60 | ±2,00 |